

Tundra Cladding



Overview

Tundra is created from New Zealand plantation Douglas Fir heart wood.

With rustic timber features and defects, Tundra Cladding is an excellent, natural choice. A fine sawn face allows a depth of grain, and optimal coating performance.

Tundra Cladding is naturally durable so does not require any chemical preservatives.

When specified and installed in accordance with the manufacturers instructions Tundra Cladding systems will achieve CodeMark status for guaranteed acceptance with New Zealand building consent authorities.

Available in a range of architectural profiles and supplied factory pre-finished in a range of Resene Woodsman waterborne exterior stains.

Wood species: Douglas Fir Heart.

Standard profiles:



Bevelback AW61 140x20mm
(110mm cover)



Rusticated AW702 140x20mm
(115mm cover)



Vertical Shiplap AW51 135x20mm
(110mm cover)

Other profiles may be available subject to minimum order quantities- please refer to Abodo Cladding Architectural Profile Chart.

Sizes:

Width x Thickness (mm)	140x20mm
	Approx. Cover
Bevelback	110mm
Rusticated	115mm
Vertical Shiplap	110mm

Lengths:

2.4 - 6.0m*

*Product is supplied as standard in 'random length' or otherwise lengths at Abodo's option. Specified fixed lengths may be available but are subject to conditions including minimum quantity, price premium and availability. Please check with Abodo prior to placement of order.

Tundra Cladding

Colours:

Colours presented are in Protector – Water Borne and are indicative only. Dark colours are not recommend in heavy weather exposed applications. Colour may change/fade as a part of the natural weathering process.



Tundra Walnut

Tundra Graphite

Tundra Manuka

Tundra Teak

Tundra Patina

Tundra Pearl

Tundra Straw

Tundra Sioox
(weathered 12mo)

*Colours are indicative only.

Product specifications

Name:	Tundra Cladding.
Quality:	Standard Grade /Sound tight knots and defects up to 1/2 of the face width, some pith and resin pockets allowed. Minimum 80% heart wood. NOTE: A range of natural and machine defects are allowed. As this is a visually graded product up to 5% of the volume may be supplied as 'out of grade', allowing for variation in grade interpretation. Some grading and cutting out of defects may be required to meet customer expectations and/or requirements of the NZBC.
Substrate colour:	Light pink/red.
Finish:	Fine bandsawn face.
Treatment:	Untreated.
Coating	Tundra must have at least one coat of stain applied all sides including back face, and two coats to the front face and edges with Protector Water Borne or other approved proprietary wood stain. Waterborne non-film forming coatings in light colour tones are recommended. Available factory pre-coated with 1 or 2 coats.
Moisture content:	Approx. 16% MC (+/-2%) at time of despatch.
Intended use:	Intended for use in residential and light commercial buildings with risk score of 20 or below as per 'Weather rightness risk matrix' in E2/AS1.
Durability:	Conforms to minimum 15 year durability performance as prescribed in the NZBC.
Serviceable life:	25 years or more when maintained according to manufacturers recommendations.
Expected dimensional change in structure:	Width expansion approx 3%, length expansion approx 0.5%, thickness expansion approx 2% (variation may occur between boards).
Density:	450-480 kg/m ³ .
Hardness:	Medium-Low (3.5kN Janka).
Weight:	~11 kg/m ² ('light weight cladding' NZS3604).
Compatibility:	Typical pH 3.5. Tundra may be corrosive on some metals including zinc. Normal PVA, PU, MUF Glues and RF resins can be used.
Certification:	FSC®- certified, No.: SGS-COC-004944.
NZBC compliance:	CodeMark Certified cladding system- certificate number CMA-CM40070.

Tundra Cladding

Product handling

- Weatherboards and accessories must be kept clean dry, under cover and out of the weather prior to installation.
- Timber must be stored horizontally on bearers at least 100mm off the ground.
- Extra care must be taken during installation so as not to damage the factory finish of the boards.
- Wear dust mask, eye protection when cutting timber.
- Tundra may be mulched, burnt or disposed of on landfill.

Fixing overview

- Timber framing is to be in accordance with NZS3604.
- Fix cladding over a water proof, breathable building wrap, rigid air barrier or other suitable waterproof substrate in conformance with NZBC E2/AS1.
- Use of a cavity system is recommended with minimum 45x20mm H3.1 battens or Cavibat (a cavity is required for CodeMark certification).
Horizontal cavity battens should be castellated (notched) and beveled to allow water run off in service. Cavity battens must be fixed to studs (vertical) or noggs (horizontal).
- Fix boards either vertically or horizontally as appropriate to the profile type specified at the following maximum batten spacings:
 - 480mm centres for vertically fixed weatherboards (Vertical Shiplap) or
 - 600mm centres for horizontally fixed weatherboards (Bevel Back, Rusticated)
- High quality stainless steel, silicone bronze fixings should be used in all cases.
Stainless steel 316 (A4) fixings should be used in areas near the sea. Pre-drill fixings using a drill bit 1/3rd smaller than the fixing.
- Use flat, rose or pentagon head ring shank nails (hand driven) to achieve minimum 30mm penetration into stud. Or use a stainless steel self countersinking self drilling screw with minimum 30mm penetration into stud.
- Allow a minimum of 2mm expansion gap between boards.
- Fixings at ends of boards must be at least 12mm from edge, and must be pre-drilled before applying fastener.
- Cut ends and notches must be sealed with 2 coats of stain or approved end sealer.
- Joins between board ends must be made over battens only, using a 35degree mitre, and application of sealant at the join eg: Sikaflex 11FC.
- For cavity systems use perforated cavity base closer flashing at base board to allow drainage, air flow and keep out vermin.
- Cladding must finish 100mm above paved surface or 175mm above un-paved surfaces.
- Use finishing mouldings backed by hemmed corrosion resistant internal flashings as required, windows, doors and where cladding meets soffit. Fix mouldings with 40mm stainless pentagon head ring shank nail (hand driven) at max 450mm centres. Seal mouldings to weatherboards and joinery with sealant eg: Sikaflex 11FC.
- A further coat of oil or stain should be applied once boards are fixed in place according to manufacturer's instructions.

Note: **The above is an overview only.**

Please refer to CodeMark Weatherboard Cladding Manual CWB-M-130925 and detail drawings at: abodo.co.nz/products for detailed installation information prior to specification or commencement of construction.

Tundra Cladding

Exterior mouldings:

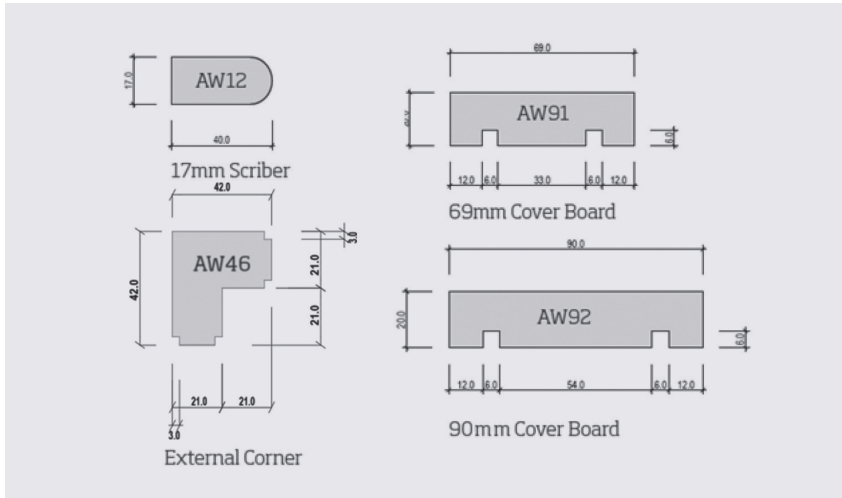

Horizontal castellated cavity battens:

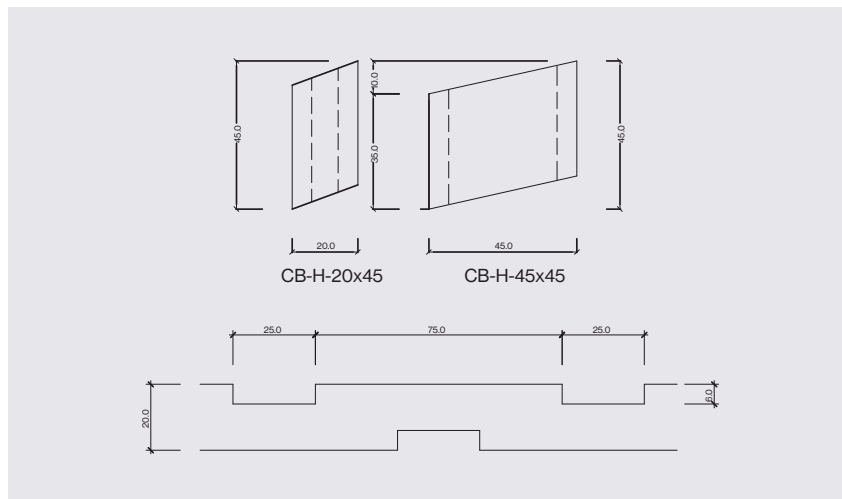

Note: Other profiles may be available subject to minimum order and should be specified according to the system being used- please refer to Abodo Cladding Architectural Profile Chart.

Maintenance

- Wash down every 12 months with gentle detergent, warm water and soft brush
- Make a maintenance check every 2 summers. Check all weatherboards, junctions, flashings, mouldings and replace or remediate as required to maintain weather tightness of the cladding system. Re-coat every 2-3 years or as required to maintain colour and integrity of coating. Re-coat period may be longer or shorter depending on climatic conditions and/or positioning of cladding to the sun.
- For heavily soiled or mouldy areas use Rejuvenator or similar oxygenating cleaner, active mouldicide and recoat with penetrating oil.
- Some board movement and surface checking should be expected on highly exposed faces.
- Resin bleed may occur as part of the natural weathering process. To remove scrape off surface resin using a tungsten blade scraper. Leave exposed sections to remain uncoated for about a week to allow for visual checks on further resin bleed from the area and oxidative hardening of the residual resin close to the surface. Touch up with coating in the appropriate colour.



Tundra – weathered 12mo

Tundra Cladding

Accessories

Abodo Protector- Water Borne 4L, 10L



P +64 9 249 0100
E info@abodo.co.nz
W abodo.co.nz